

# CarTAG – CarCommunication via RFID

## Data generation

- mileage
- Fill levels
- operational time
- Telemetry
- **VIN**
- Fault memory
- Diagnosis
- User
- ....

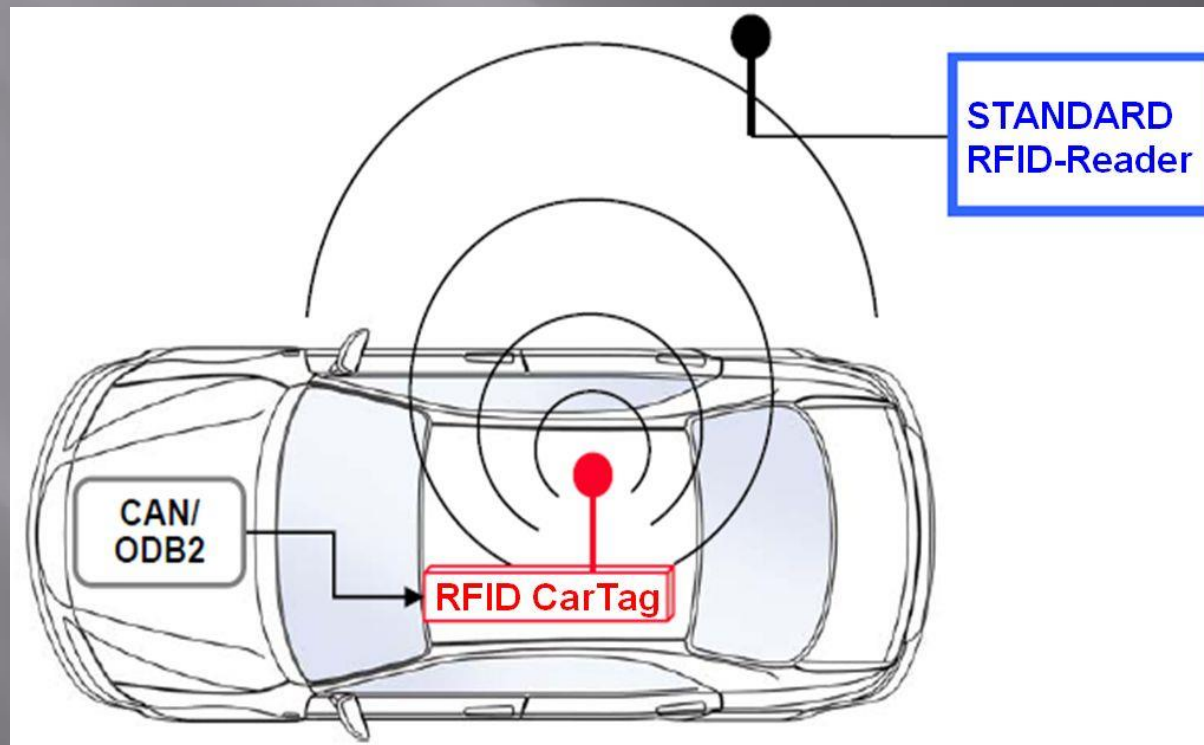

## Data analysis

- Driving data
- Diagnosis data
- **Identification**
- ....

# CarTAG – CarCommunication via RFID

---

- UHF EPC C1 Gen2 conform
- Standard RFID-infrastructure
- To the outside: a passive Gen2 TAG
- To the inside: a communication device with the vehicle bus
- Interesting for car parks, rental cars, freight forwarders, taxis ...
- Automatic transmission of vehicle data
- Offline parameter setting
- Customized firmware on request

# CarTAG – CarCommunication via RFID

- UHF - Standard RFID-TAG
- EPC 128 bit
- Datarate up to 640 kbit/s
- e.g. FRAM - User-Memory 1,5 kByte
- Authentication with password
- Configuration of Memorysegments
- Encryption e.g. with AES 128 bit
- Active: < 10 mA on board voltage
- Halt Mode < 1 mA
- CAN up to 500 kBaud

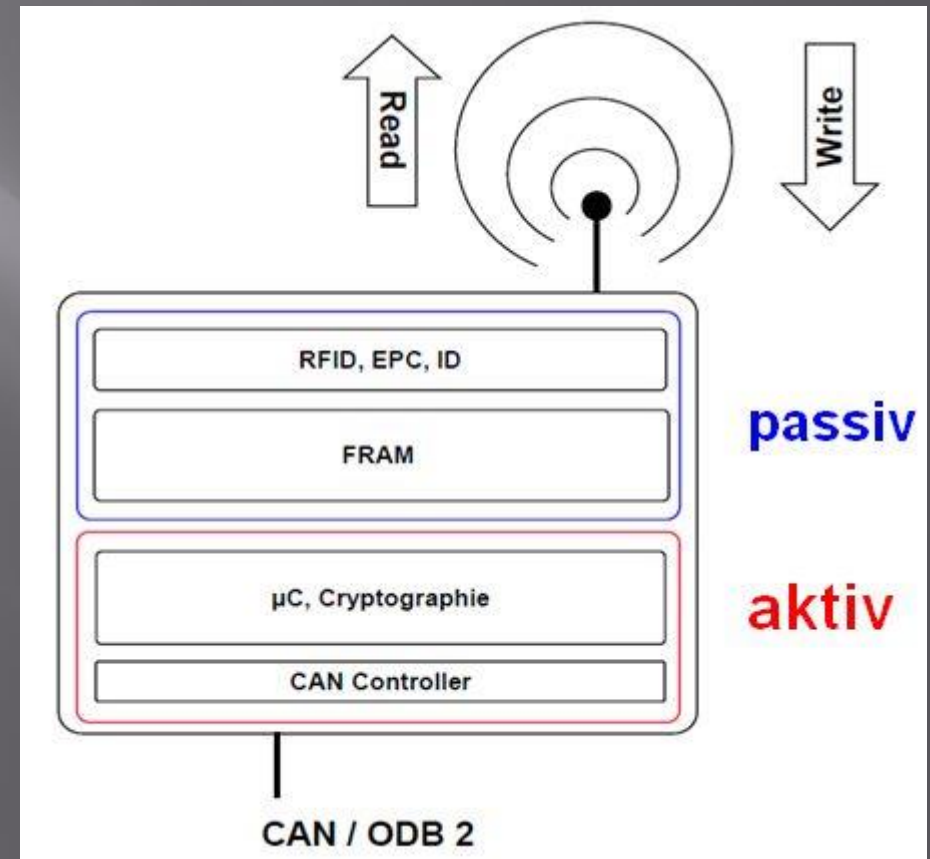

# CarTAG – CarCommunication via RFID

- ODB 2 standardcommands
- CAN messages with any control devices
- Memory config: Lock for read/write
- Memory mapping Plain / Secure
- e.g. AES encryption of stored data Key transfer during installation
- Secret key in database

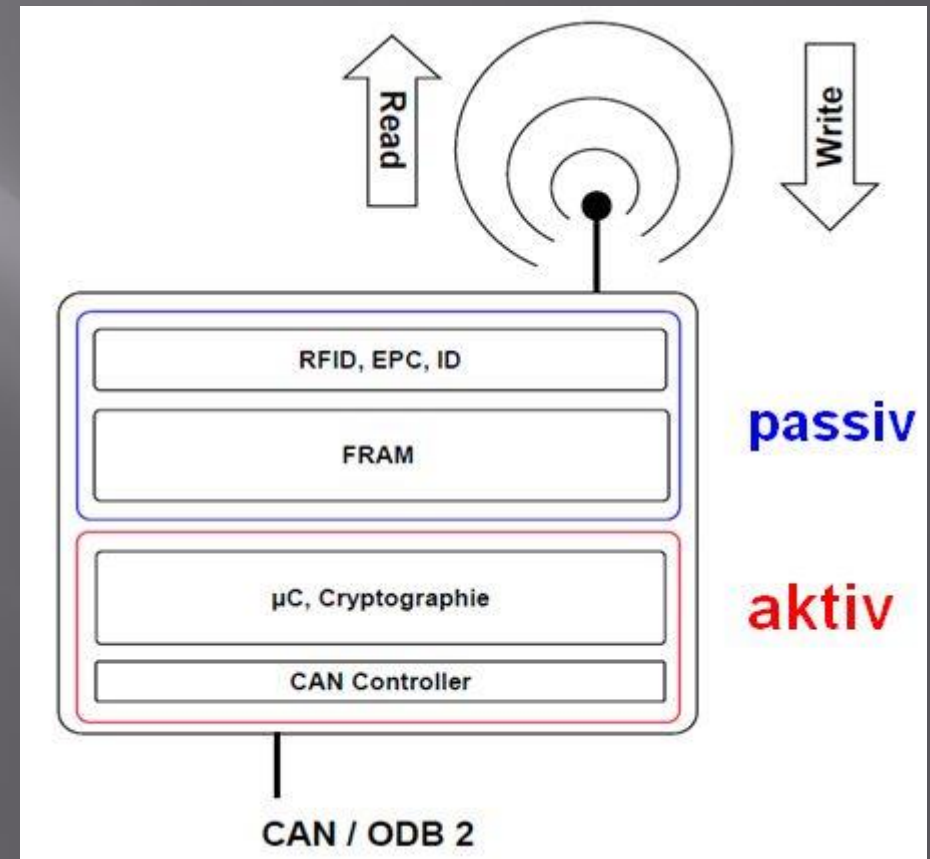

# CarTAG – CarCommunication via RFID

---

## Application examples

### **Rental Cars**

On return, when an antenna is crossed, mileage, tank filling, exceeding of other operating parameters are detected automatically

### **Car workshops**

The vehicle is detected at the entrance and fault conditions are transmitted directly - when the customer disembarks, all important information is available to the customer service staff

### **Immobilizer on the parking lot of the manufacturer**

Vehicles can be blocked or unlocked in the parked state

### **Machine maintenance**

Machines such as elevator systems or machine tools can also be maintained and parameterized by means of RFID from a handheld device via this system

# CarTAG – CarCommunication via RFID

## Functional Prototype

